

installation and operating manual



contents

	page
description	3
installation	4-5
information	6
wiring information	7
protocol set up	8-9
communication connections	10
technical specifications	11
on screen programming of the meter	12-13
operating instructions	14-15

evo ic³

description

check your contents

It should contain the following:

- 1 installation and operating manual
- 1 graphical display unit
- 1 base module
- 1 interconnecting lead
- 2 fixing clamps



fixing clamps

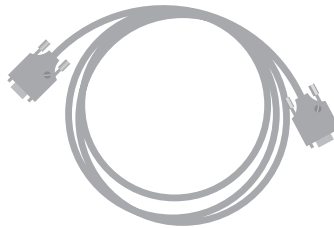

interconnecting lead
(2 metres in length)

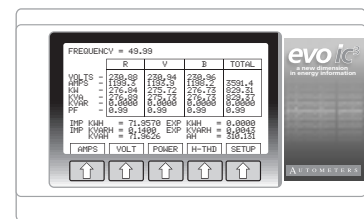

graphical display

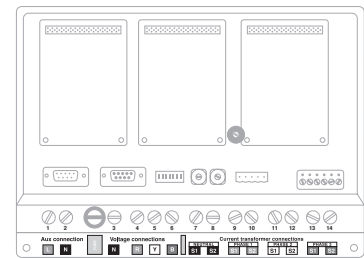

base module

overview of the unit

The evo ic³ is designed to satisfy the most demanding metering requirements of engineers worldwide. Autometers has used the latest graphical display and microprocessor technology to build a precision multifunction meter which combines many desirable features with cost-effectiveness.

The evo ic³ delivers exceptional functionality. The meter displays many electrical parameters on one screen. It also has the capability of setting and displaying multiple alarm points, which trigger relays to close. The evo ic³ is built on a very stable platform, enabling high sampling – in excess of 1000 samples per cycle at 50Hz.

This enables high resolution RMS calculations, and high level Harmonic Analysis – which is limited to the 63rd Harmonic.

The evo ic³ offers accurate and reliable measurement. It can also transmit information to energy monitoring systems in a number of different formats, without diminishing the accuracy of the metered data.

The evo ic³ has a unique 1Mb memory facility for logging data.

evo ic³

installation

mounting the display and base unit

installation of the display unit

Mount the meter so that the front panel is vertical. A typical panel would be a switchgear cabinet door. The meter requires depth behind the panel of 60 mm excluding wiring. Prepare a single square hole 92mm wide and 92mm high.

location

The evo ic³ series should be mounted in dry dirt free environments away from heat sources and very high electric fields. Temperatures should not exceed 70°C or fall below -20°C.

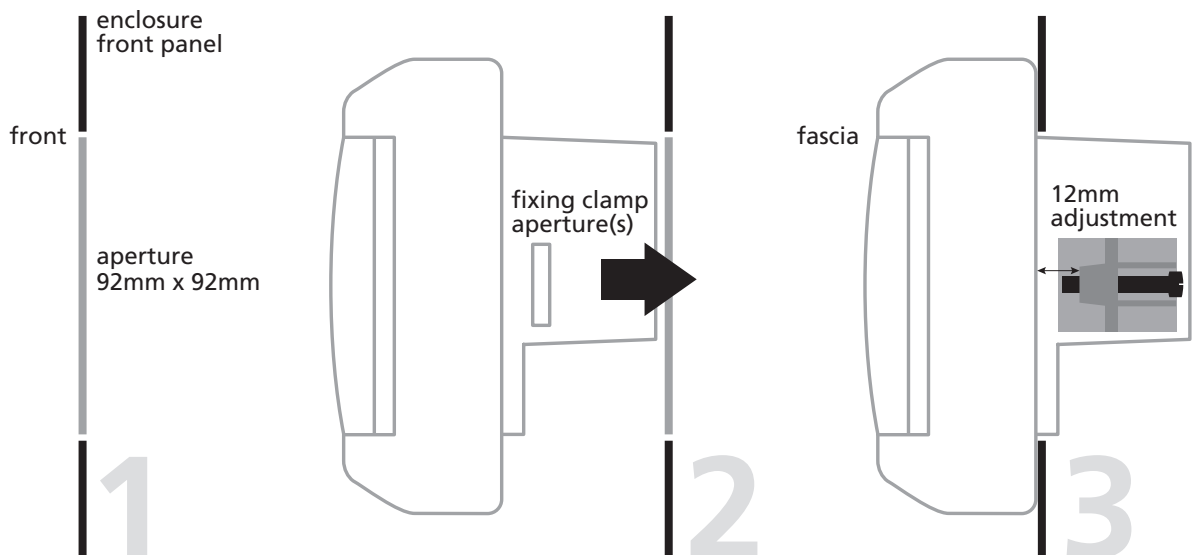
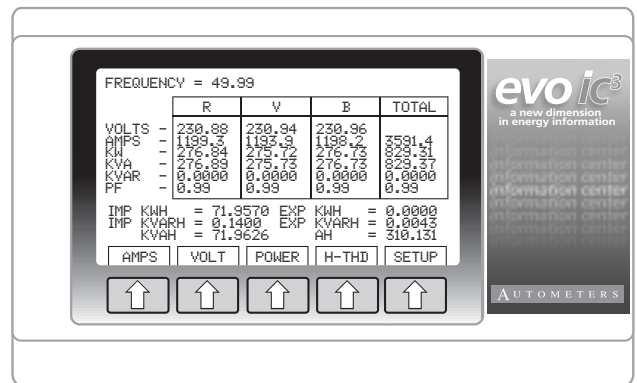

1. Cut aperture in enclosure front panel 92mm wide x 92mm high.
2. Slide unit through aperture.
3. Insert fixing clamps and screws, one either side. Tighten carefully.

evo ic³

installation

mounting the display and base unit

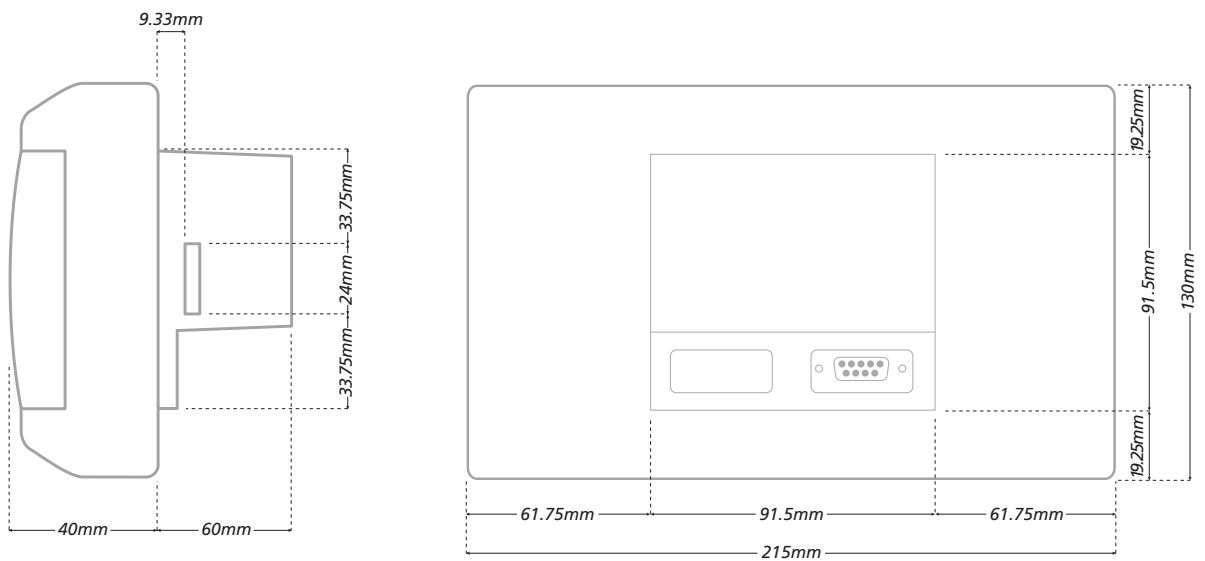

installation of the base unit

Before fixing the base unit ensure the interconnecting cable will reach the display unit. Length of cable is 2 metres. (Longer lengths are available on request.)

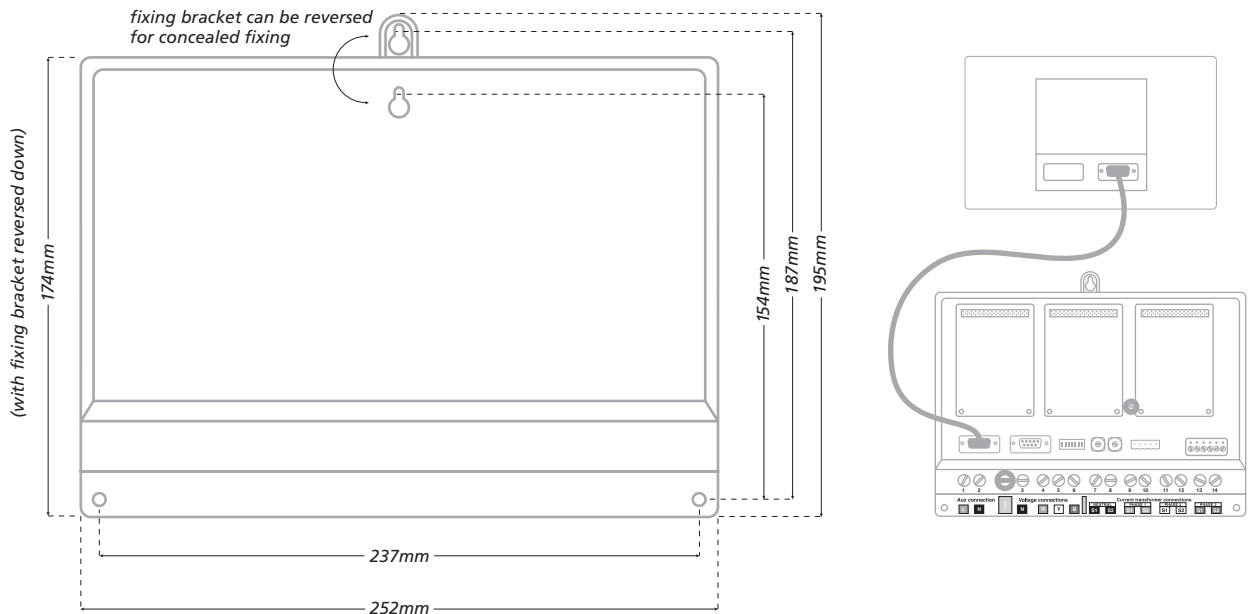



information

about the display and base unit

display

240 x 128 backlit graphical display. To activate display light, press any key. Light remains on for 5 minutes after last key press.

information access keys (arrow keys)

Used to access more indepth information.

programming keys

Visible only when door is opened. 11 keys in total. 1-0 and decimal point. Used to programme the meter.

special allocation keys S1, S2, N

These three keys are special function keys and can only be programmed by Autometers.

S1 shows Autometers contact information.

N is network exit key (used for remote display only).

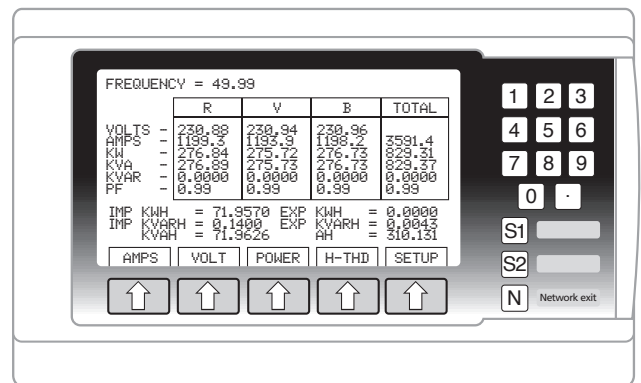

A. display socket

D type 9 pin socket (male) display output.

B. programming socket

D type 9 pin socket (female) used by Autometers for internal programming of micro processors.

C. protocol setup

7 way dip switch used as binary switches numbered 1-7. See page 9 for protocol set up.

D. RS 485 modbus address

Two hexadecimal switches for individual numbering of the meter. See page 8 for setting.

E. RS 485 connection

5 way terminal connector (plug and socket). See page 10 for connections.

F. pulse outputs

3 energy outputs, KVArh, KVAh, KWh. See page 7 for connection details.

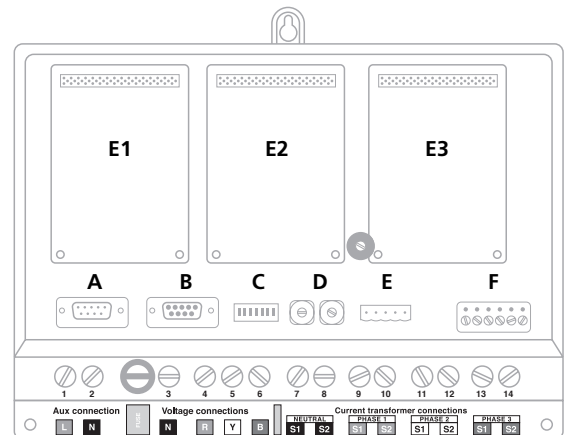

optional

E1, E2, E3

3 expansion sockets for optional plug-in cards. Available: 3 x 4 channel 4.20mA output (total 12), 3 x 4 alarm output relays (total 12), 1 memory card 1 Mb. Expansion cards can be mixed. eg. 1 4.20mA, 1 relay, 1 memory.

terminals

1, 2

Auxiliary voltage supply.

3

Neutral supply.

4, 5, 6

Phase voltage.

7, 8, 9, 10, 11, 12, 13, 14

Terminals for external current transformers.

fuse

Protects auxiliary voltage.



wiring information

power supply

The standard evo ic³ Series meters are powered by 230 volts AC (47 to 66 Hz) at 0.2 amps. The units can be powered from a dedicated fused supply or may be powered by the voltage source which they are monitoring, as long as it is a 230 volt system. As an option the meter can be supplied with a 110 volt power supply. A removable protection fuse for the auxiliary power supply is fitted in the meter.

wiring

Electrical and communications connections are made directly from the front of the base unit. Electrical connections are made to terminals 1-14, pulse output relays and the RS485 terminals are located on a higher level and numbered accordingly. See diagrams below.

electrical connections

2.5mm² wire is recommended for all electrical connections. Phasing and polarity of the AC current and voltage inputs and their relationship are critical to the correct operation of the unit.

evo ic³ 3 phase 3 wire wiring diagram

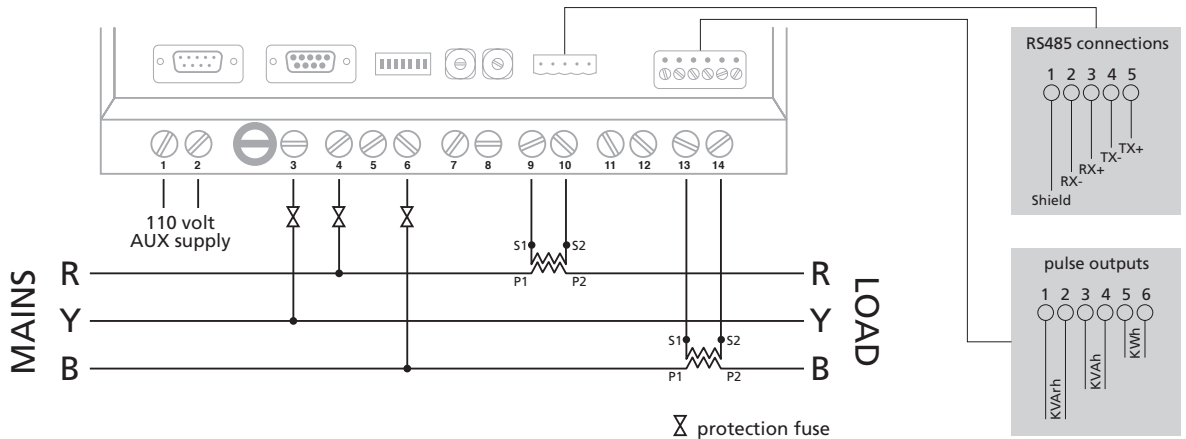

evo ic³ 3 phase 4 wire wiring diagram

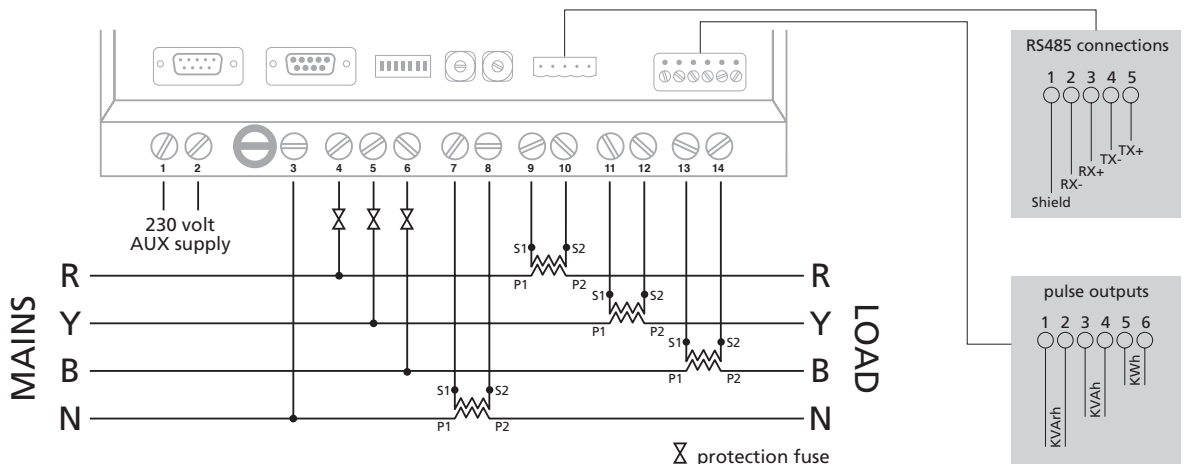

evo ic³

protocol set up

removing the cover to alter protocol settings

Remove screw. Lift from the bottom of the cover and slide upward to remove cover.

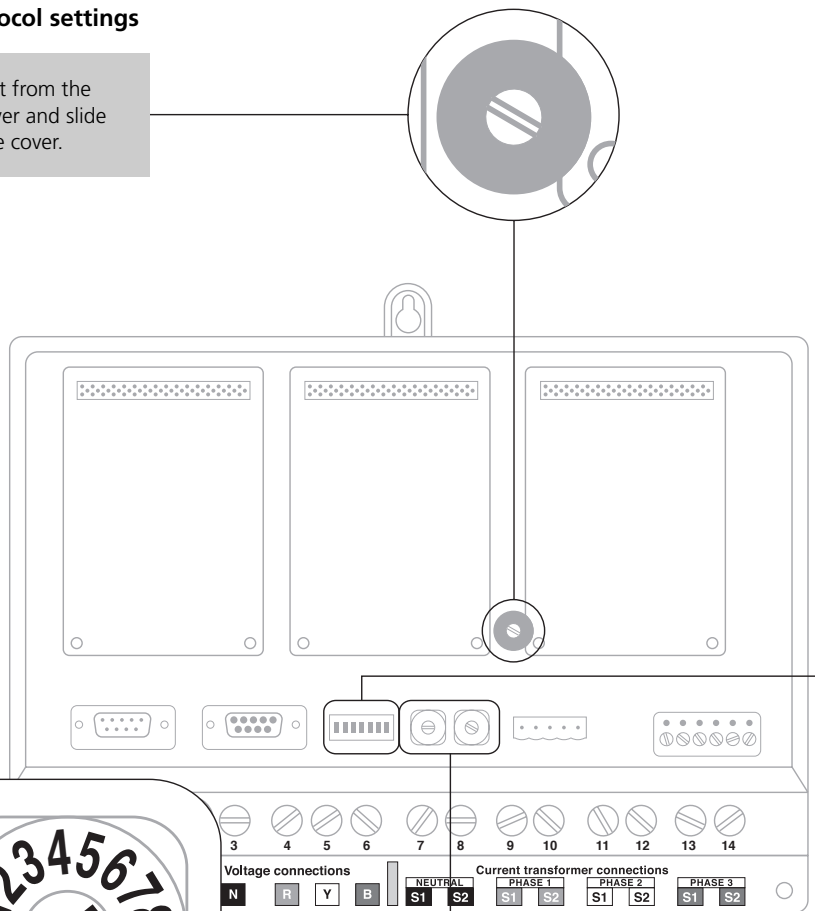

RS485 modbus address

The position for the modbus address switches are shown below. These switches allow the meter to have a unique number up to 128.

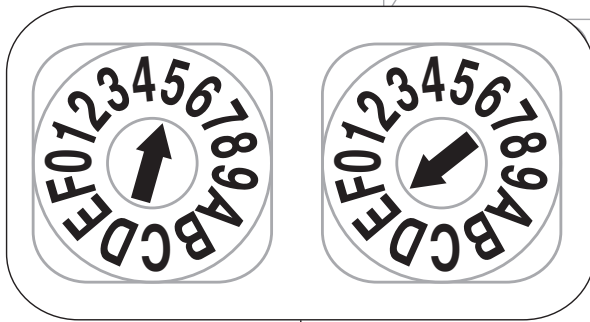

Using the key below adjust the two rotary hexi-decimal switches. eg. a meter which requires a number setting of 94 will require the left switch to be set to 5 and the right switch to E (5E)

left switch key

1 = 16	4 = 64	7 = 112	A = n/a	D = n/a
2 = 32	5 = 80	8 = n/a	B = n/a	E = n/a
3 = 48	6 = 96	9 = n/a	C = n/a	F = n/a

right switch key

1 = 1	4 = 4	7 = 7	A = 10	D = 13
2 = 2	5 = 5	8 = 8	B = 11	E = 14
3 = 3	6 = 6	9 = 9	C = 12	F = 15



protocol set up

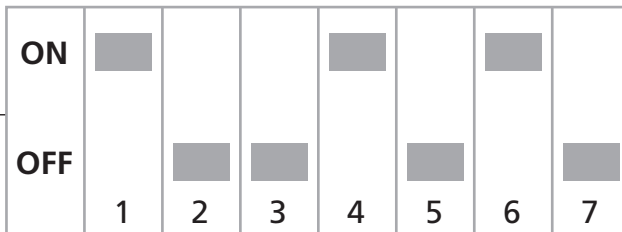

binary switch

When using the 485 communication connection it is essential that the protocol binary switch and the modbus address switches are set correctly. This is done by first removing the clear cover and then setting the switches. See *diagram*.

The position of the binary switch is indicated on page 6 section C (protocol set up).

example of setting above

switch no		on/off	
1 & 2	baud rate	(1) on / (2) off	19200
3	wire mode	off	2 wire
4	modbus type	on	RTU
5	4 wire parity	off	even
6	format mode	on	floating point
7	floating point	off	FP low word first

switch settings (options available)

switch no		on/off	
1 & 2	baud rate	(1) off / (2) off	9600
		(1) on / (2) off	19200
		(1) off / (2) on	38400
		(1) on / (2) on	–
3	wire mode	off	2 wire
		on	4 wire
4	modbus type	off	ASCII
		on	RTU
5	4 wire parity	off	even
		on	odd
6	format mode	off	ASCII string
		on	floating point
7	floating point word format	off	FP low word first
		on	FP high word first

For all switch setting options available please refer to the table on the left.



communication connections

RS485 connection

This connection should be made using the appropriate screened twisted pair cable (22 gauge Belden 8761 or equivalent). It is imperative that the terminals are wired as per the diagrams below.

evo ic³ 2 wire modbus wiring

In **2 wire** mode all node transmitters are connected together and linked to the host transmitter port and all node receivers are connected together and linked to the host receiver port.

evo ic³ 4 wire modbus wiring

In **4 wire** mode all node receivers are connected together and linked to the host transmitter port and all node transmitters are connected together and linked to the host receiver port.

evo ic³ 2 wire modbus wiring diagram

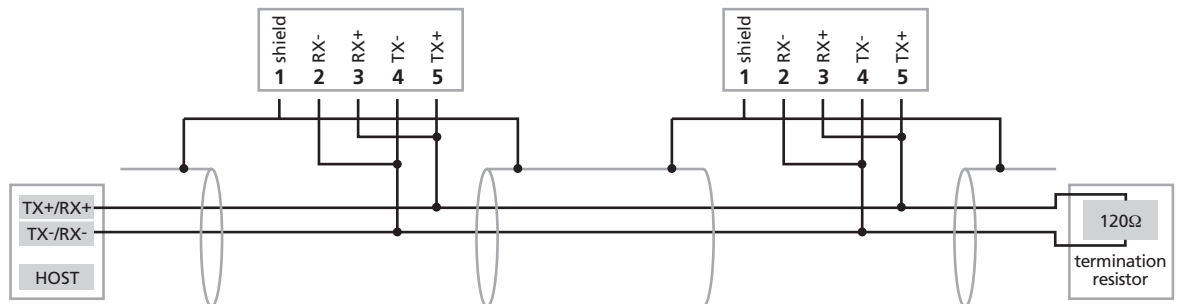

evo ic³ 4 wire modbus wiring diagram

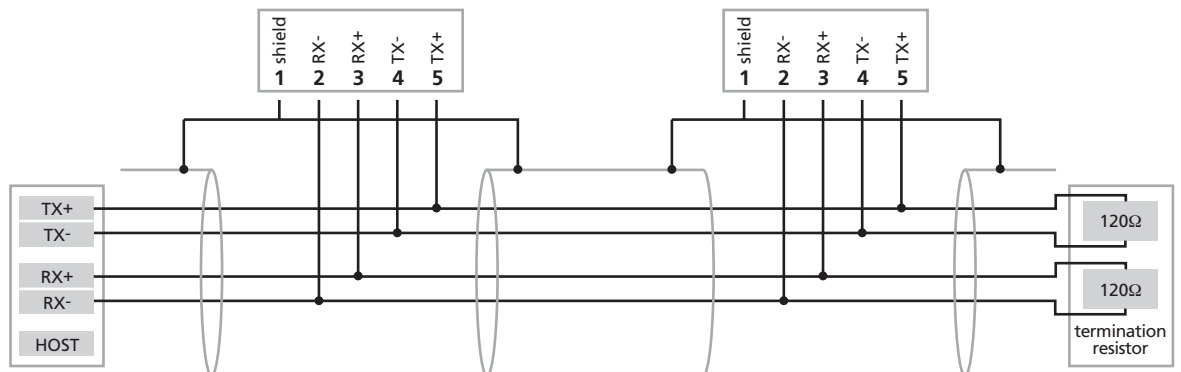

- 22 SWG shielded BELDEN 8761 or equivalent
- Maximum 128 nodes per network
- Total length of connecting cable not to exceed 1000 metres

caution

It is important that the shield **must** be earthed at **one end only**.



technical specifications



certificate no. 0275

display

graphical display 240 x 128 dot matrix
FSTN black on white LCD
transmissive, wide temperature type

membrane switches (typical characteristics)				
electrical properties	min	typ	max	units
contact resistance	–	100	–	Ohms
switch capacitance	–	<25	–	pF
		per switch		
operating voltage	0.5	–	50	volts
operating current	0.05	–	100	mA
switching power (rating)	–	–	1.0	watts
insulating resistance (at 100 volts)	10	–	–	M.Ohms
dielectric strength	–	500V RMS @ 50 Hz	–	–
contact bounce				
polyester domes		<20ms		
mechanical properties				
life expectancy	polyester domes		3 million operations	
operating force	polyester domes		75-700 gram	
environmental properties				
operating temp	polyester domes		-20°C to +70°C	
storage temp			-40°C to +70°C	

accuracy

(KWh) all energy measurements comply to BSEN61036 class 1.0

burden

less than 1Va

aux. burden

less than 10 Va

accuracy drift

negligible, self compensating circuit built in

aux. supply

230V AC +/- 10% 110V AC +/- 10%

maximum measuring voltage

300V AC phase to neutral 520V AC phase to phase

rated current

5-6 amps (fully isolated)

operating frequency

45-65 Hz

temperatures

operating temperature -20°C to +70°C
storage temperature -30°C to +80°C
humidity 20-90% RH non condensing

volt free relays

The type of relay used in the *evo ic³* is the solid state optically coupled with MOSFET technology incorporated. This device offers the superior reliability associated with semiconductor devices, ensures enhanced input to output isolation and faster bounce free contacts.

energy relays fitted

3 as standard KWh, KVAh, KVARh

pulse length

default value 100ms (programmable)

pulse value

low voltage 230/400V default 1 KWh, 1 KVARh, 1 KVAh
high voltage 110V default 10 KWh, 10 KVARh, 10 KVAh

relay contacts

max switching voltage 600VDC or PEAK AC
max switching current 100mA
on resistance 50 Ohms

communication output 485

type Raicon 5 way plug and socket
material polyimide 66, flame resistant & self-extinguishing

protocol and baud rate settings

surface mount dip switch (7 position binary switch)
series 90HB SPST low profile

standards – EMC testing for emissions and immunity

BSEN 61000-4-2 BSEN 61000-4-3 BSEN 61000-4-4
BSEN 61000-4-5 BSEN 61000-4-6

evo ic³ material

display housing	front/back cover & opening door	abs flame retardant
base unit housing	top/middle & terminal cover	clear polycarbonate
	black base & fixing bracket	abs flame retardant

graph showing *evo ic³* accuracy load curve

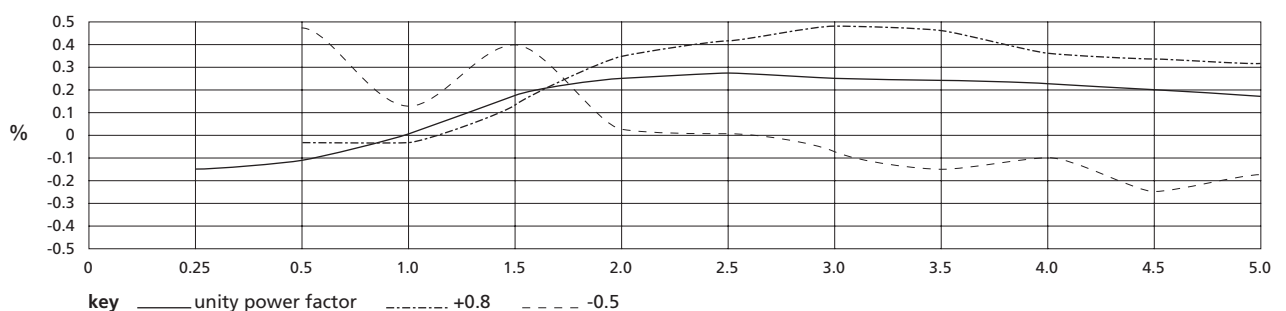

evo ic³

on screen programming of the meter

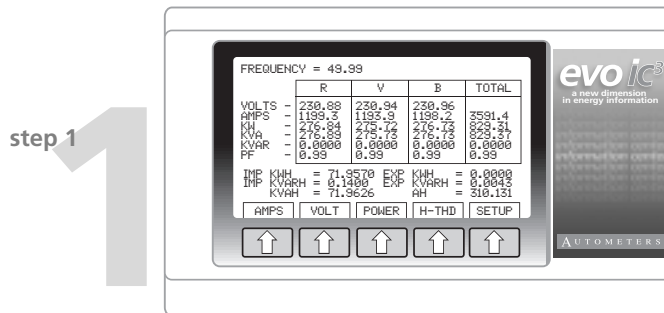

When the meter has been installed and power has been applied to the meter the display will run through a set up routine and default to the main screen. You can now start to programme the meter.

Ensure the screen is showing main as shown in diagram

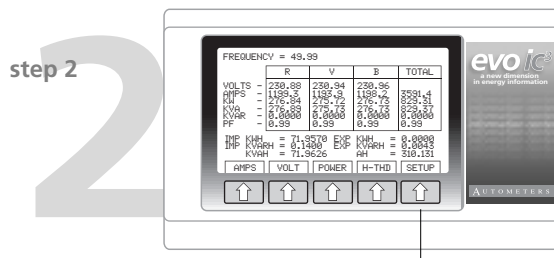

Press **SET UP** (bottom right of screen)

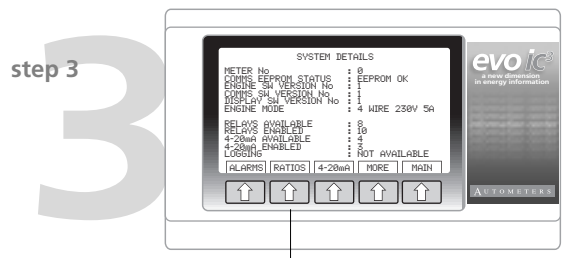

Press **RATIOS** (bottom)

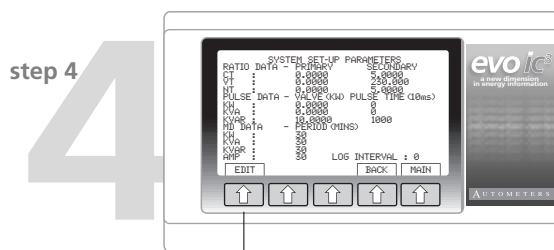

Press **EDIT** (bottom first left)

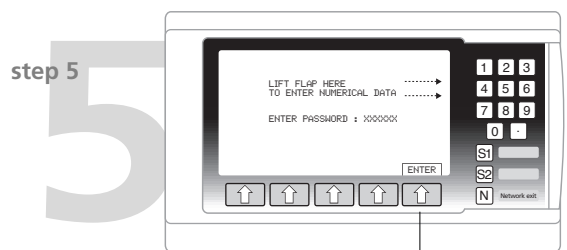

Enter password (password is the serial number on the front of the base unit)
See example below.



evo ic³

now you are ready to edit and enter your required values

please read screen carefully

You are about to enter a multiple field editing screen. To help you move around this screen there are a set of editing keys which have the following operation.

- EXIT** Leaves the editing mode
- LAST** Move cursor to previous field (does not erase present field)
- NEXT** Move cursor to next field (does not erase present field)
- BACK** Move cursor back one space
- ENTER** Terminate field and erase all other characters in field

If you edit a field always use ENTER key.

Press any key to continue.

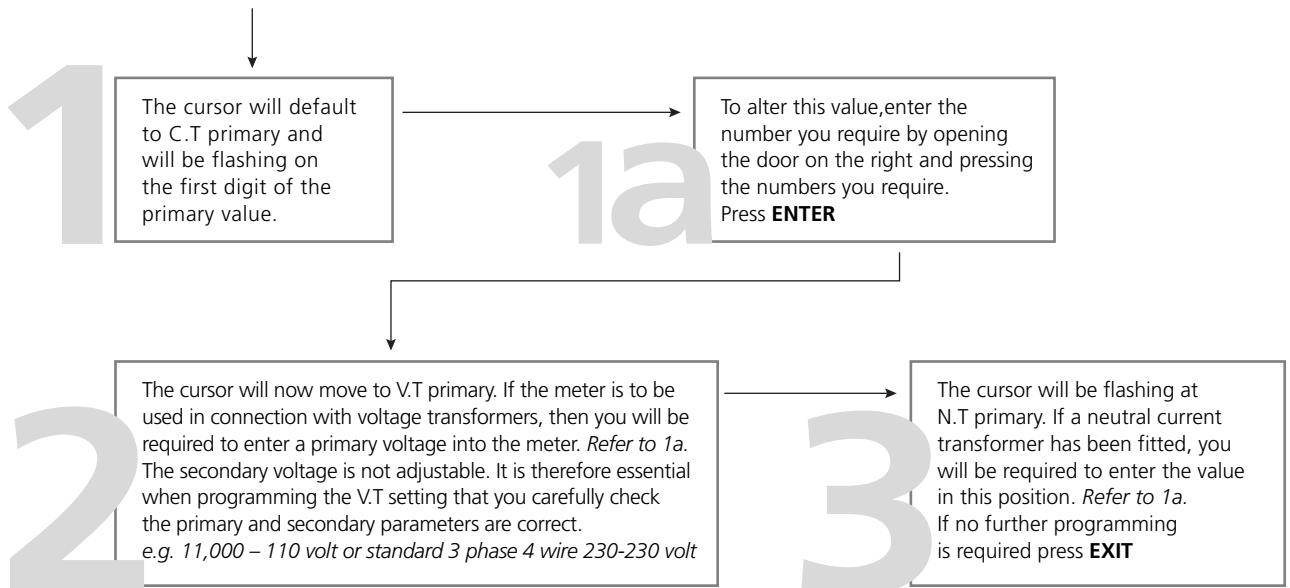
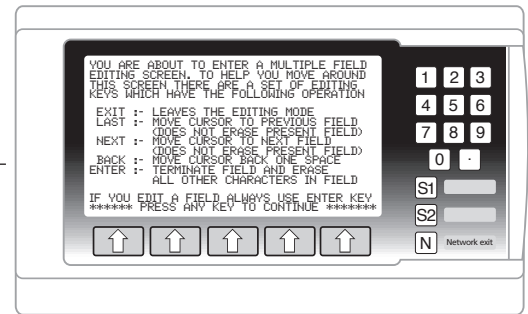

pulse data

The evo ic³ allows you to change the pulse value and the time the contacts are closed. To alter these values follow steps 1-6 (see page 12), press **NEXT** until the cursor moves down and is flashing on the position you want to alter. Refer to 1a.

maximum demand data

The evo ic³ allows you to change the time of the reset period of the maximum demand registers. To alter these times follow steps 1-6 (see page 12), press **NEXT** until the cursor moves down and is flashing over the position you want to alter. Refer to 1a.

log interval

The log interval is also adjustable, this can only be altered if the meter has been fitted with a memory card. (See separate instructions for installing expansion cards.)

When all the data has been entered press **EXIT**. The screen will show DATA SAVED IN MEMORY and return to system set up for you to check.

If all the details are correct press **MAIN**. This will return you to the main menu.

evo ic³

operating instructions

The evo ic³ has been designed to display the main electrical parameters on one screen thus enabling at a glance to monitor power fluctuations.

The evo ic³ has many other electrical parameters such as Maximum Demand, Under and Over Alarm points settings and Current and Voltage Harmonic analysis. This information is displayed on other screens available by pressing the arrow keys located below the screen.

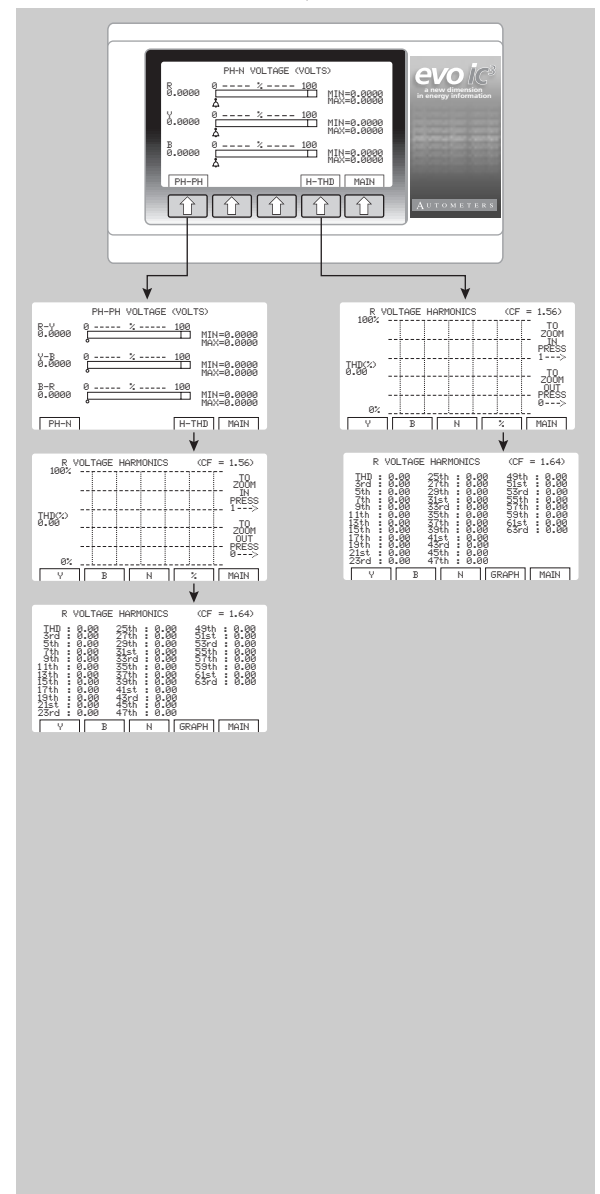
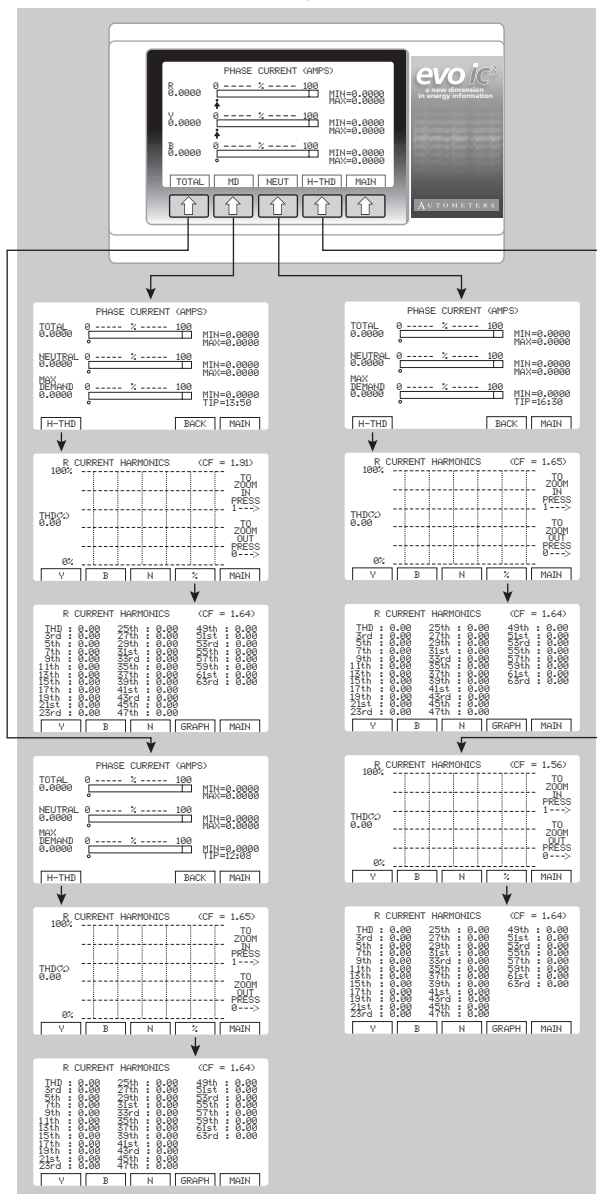
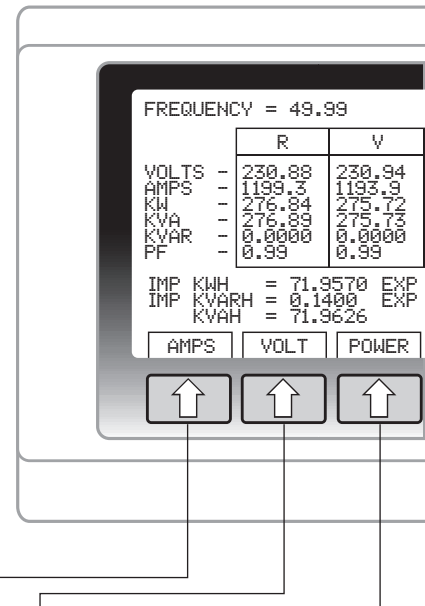

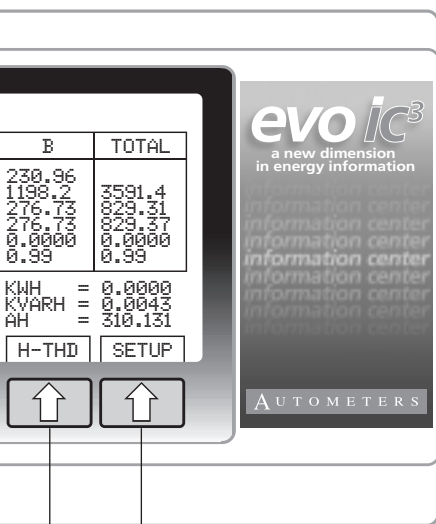

SET UP see page 12-13

main display screen

The picture to the left is showing all the electrical parameters available on the main screen. The diagram below indicates the route which will guide you to the various other fields of electrical information.

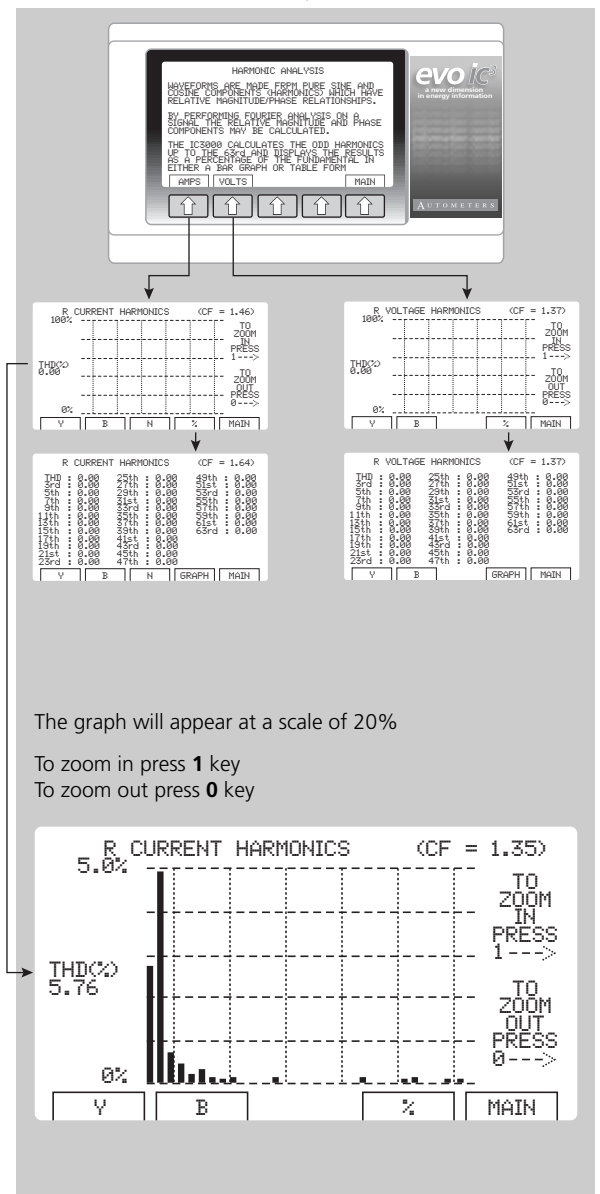
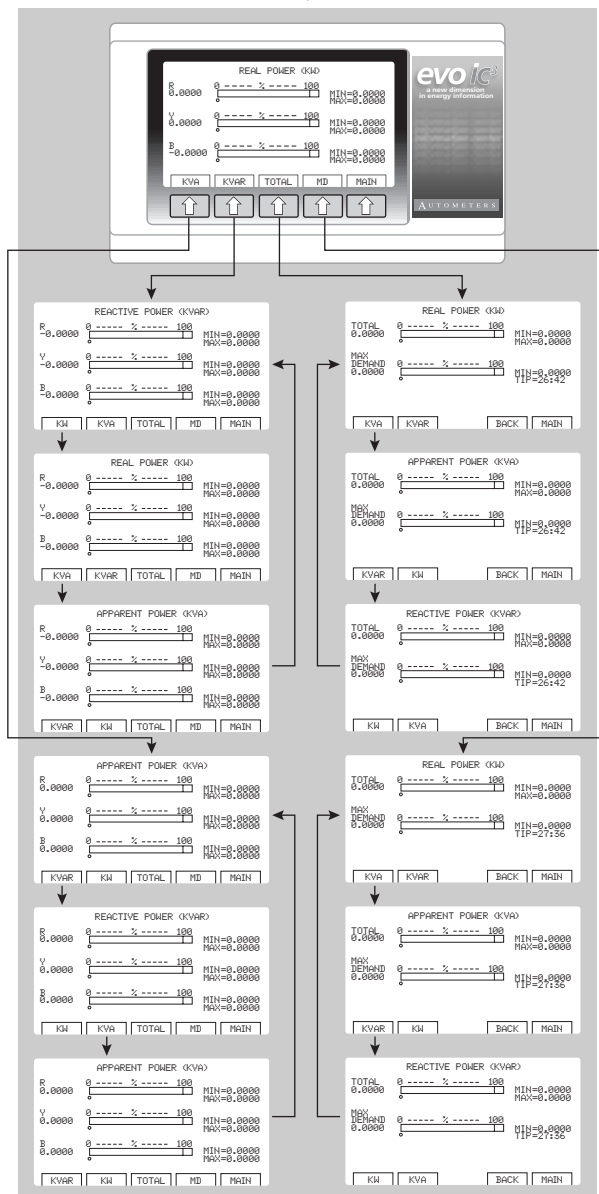

AUTOMETERS

4b Albany Road, Chorlton-cum-Hardy, Manchester M21 0AW Tel: +44 (0) 161 861 9056 Fax: +44 (0) 161 881 3745
email: sales@autometers.co.uk www.autometers.co.uk

Try our **virtual meter** on the product website www.evo-ic3.co.uk

evo ic³ an evolution for metering a **revolution for information**

